



# ALIAMAG

## Converter For Electromagnetic Flowmeter

### Model AMC2100 Series

## GENERAL

**ALIAMAG** The Aliamag AMC2100 series converter is a microprocessor based intelligent transmitter that can be paired with any of the Alia AMF series sensors. The unit features multiple display parameters including flow rate, flow total, diagnostics, programming and troubleshooting.

## FEATURES

- ☐ Three line LCD display Flow Rate / Totalizer
- ☐ Accuracy of +/-0.4% value of reading
- ☐ Bi-directional flow measurement, current and pulse output
- ☐ Large digital display
- ☐ MODBUS/HART communication



## STANDARD SPECIFICATION

- Excitation : DC pulsed
- Display : 3 lines LCD with illumination
  - Line 1 : 11 digit totalizer for forward flow
  - 11 digit totalizer for reverse flow
  - 11 digit totalizer for difference
  - Line 2 : 5 digit flowrate / velocity / % / mA / HZ
  - Line 3 : Parameter / Query / Clr tot / Query LOG
  - Alarm, Guidance
- Totalizer Unit : T, Kg, g, lb, Ston, Lton, m3, L, mL, lgal, gal,
  - Mgal, bbl, fr3, a-ft
- Time Unit : sec, min, hour, day
- Measuring Range : Min. 0 to 0.15 m/s
  - Max. 0 to 15 m/s
- Accuracy : +/-0.4% of reading (Velocity ≥ 0.5 m/s)
  - +/-0.002 m/s (Velocity < 0.5 m/s)
- Repeatability : +/-0.1% of reading
- Current Output : 4-20 mA (Isolated)
  - Load : Max. 600 Ω
- Pulse Output : Open collector
  - Rating : 3 to 30 VDC, 20 mA Max.
- Pulse Rate : 1)Scale pulse (Pulse/mL, Pulse/L, Other)
  - 2)Frequency: 0-5000 Hz
- Pulse Width : 50% of band width
- Alarm : High/Low with open collector output
  - Rating : 3 to 30 VDC, 20 mA Max.
- Communication : RS485 (MODBUS Protocol)
  - HART signal (Compatible)
- Keypad : 3 external keys for programming and display control
- Data Storage : Operation parameters and totalizer figures are stored by EEPROM for more than 10 years
- Low Flow Cutoff : 0 to 9.9 %
- Damping : 0 to 99 Seconds
- Density Setting : 0.1 to 9.99 g/cm3
- Self Diagnosis : The following error message are displayed if failure occurs
  - Coil failure
  - Power failure
  - Overranged output
  - Internal error
  - Overflow
  - Empty pipe
- Cable Entry : Standard :PG11 Option:1/2"NPTF
- Protection Class : IP 65
- Ambient Temperature : -25 to +65 °C
- Material : Aluminum Alloy
- Power Supply : 90-260 VAC, 50/60 Hz
  - 24VDC +/-10% (Option)
- Power Consumption : 3-17 W (Dependent on sensor size)
- Weight : 1.4 Kg
- Mounting : Wall mounting
  - Bracket on 2" pipe



## ALIA TECHNOLOGY LLC

633 W. 5th Street, 26th Floor, Los Angeles, CA 90071, USA  
 TEL : + 1 - 213 - 533 - 4139 FAX : + 1 - 213 - 223 - 2317



URL : [www.alia-inc.com](http://www.alia-inc.com)  
 E-mail : [alia@alia-inc.com](mailto:alia@alia-inc.com)  
 AMC2100V1.2.1.r1.A4.en

**➤ DIMENSIONS**

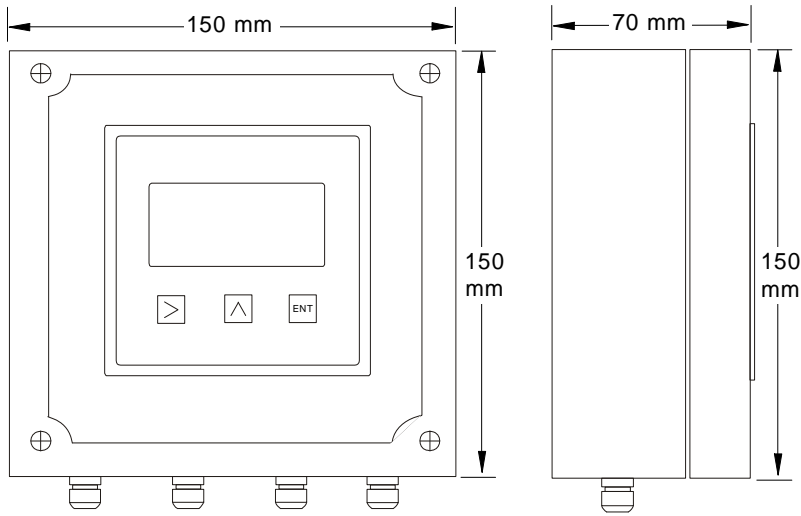

**➤ WIRING DIAGRAM**

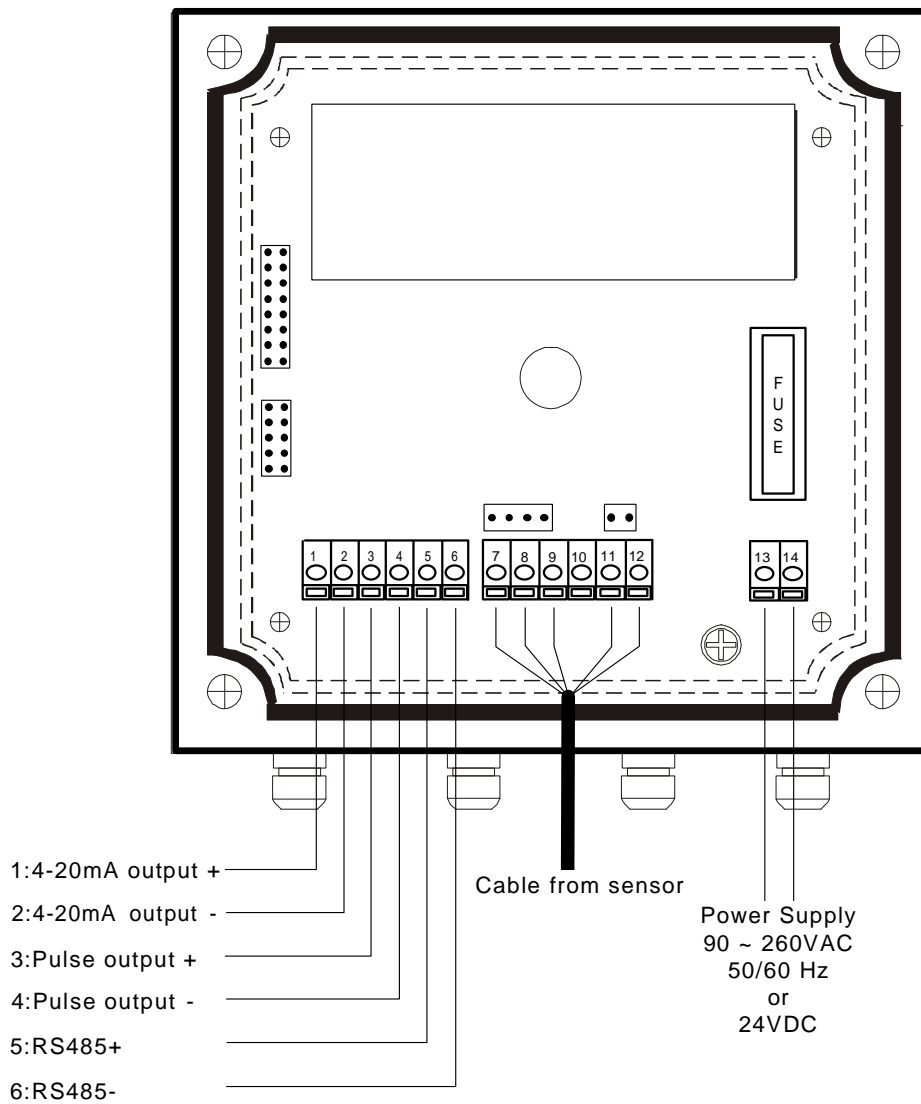

**➤ ACCURACY**

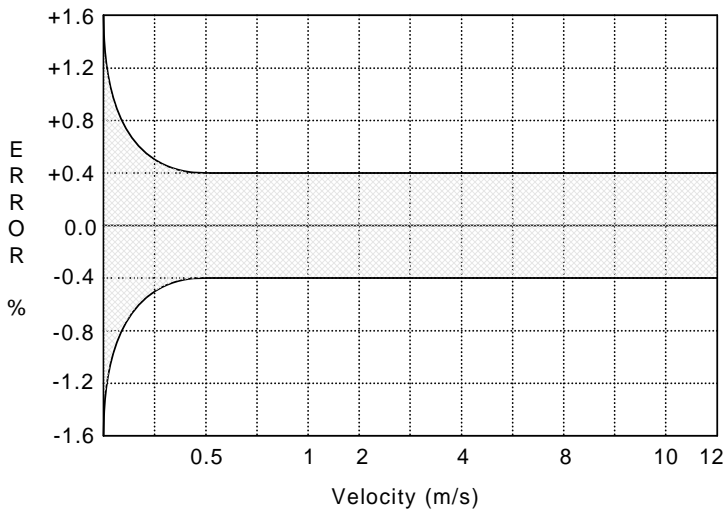

**➤ CABLE LENGTH BETWEEN SENSOR & CONVERTER**

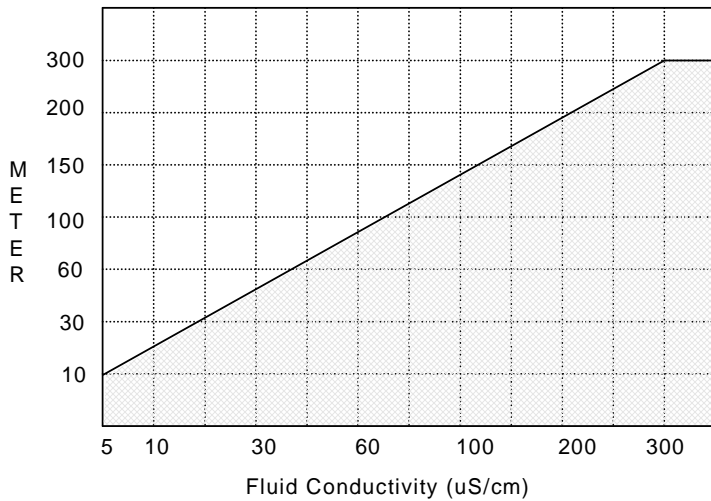

**➤ MODEL SELECTION GUIDE**

AMC2100 Series					
Example: AMC2100-AC-CP-HT-NN					
AMC2100-	XX-	XX-	XX-	XX	Description
Power supply	AC-				90-260 Vac, 50/60 Hz
	DC-				24Vdc, +/-10%
Mounting		CP-			Compact with Sensor
			SW-		Separate, Wall Mounting
				S2-	Separate, 2" Mounting Bracket
Communication			NN		RS485 (MODBUS Protocol)
				HT	HART Signal (Compatible)
Option			NN		None
				PT	Cable Entry 1/2" NPTF

**➤ BUILD OPTIONS-(COMPACT OR REMOTE)**

