

Mechanical Float Level Switch Series: MLS



The Series MLS Mechanical Float Level Switch provides highly accurate and repeatable level readings in a wide variety of liquid level measurement applications. The large, buoyant and robust float of the MLS allows it to be used in harsh applications where fouling or buildup might otherwise be of concern.

Features

- Direct pump control
- Adjustable On/Off switching levels
- Simple installation
- Field adjustable probe length

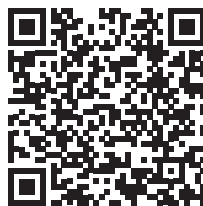

MLS Specifications

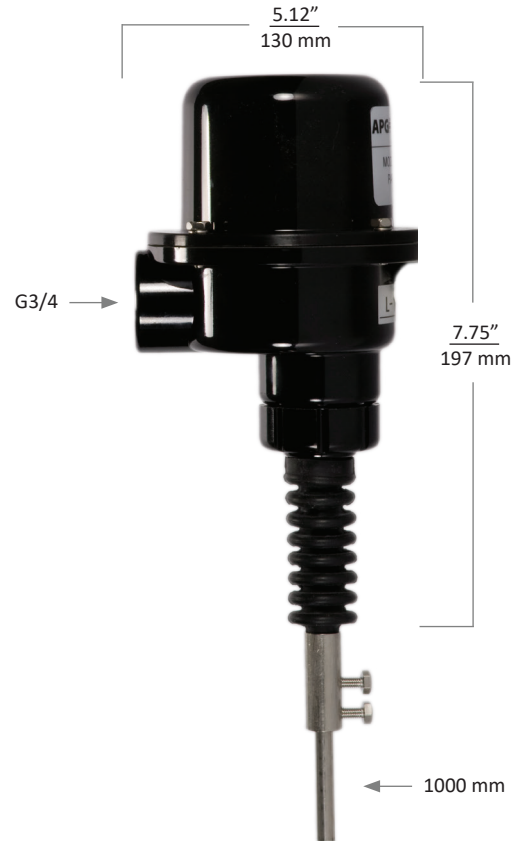
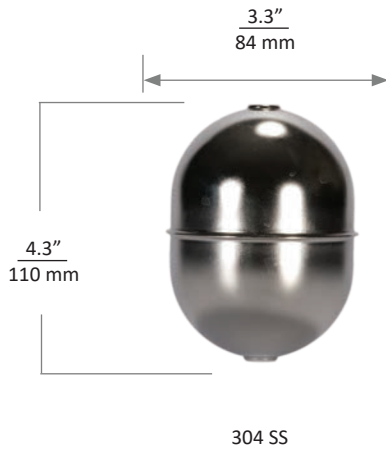

Performance

- SPDT miniature switch

Connectivity

- Output Contact Rating:
250 V 10 A AC; 250 V 0.4 A DC (resistive)

Environmental

- Operating Temperature:
-32° - 176°F (0° - 80°C)
- NEMA 1, IP42

Certification

- NEMA 1, IP42

Physical

- Housing: Polycarbonate
- Stem: 304 SS
- Float: 304 SS
- Protective Bellows: Neoprene/Silicone

Model Configuration Options

Model Number: MLS - 2S - -
 A B

A. Protective Bellows

- Null** Neoprene
- S** Silicone

B. Rod Length

- 1000 mm (for longer contact factory)